

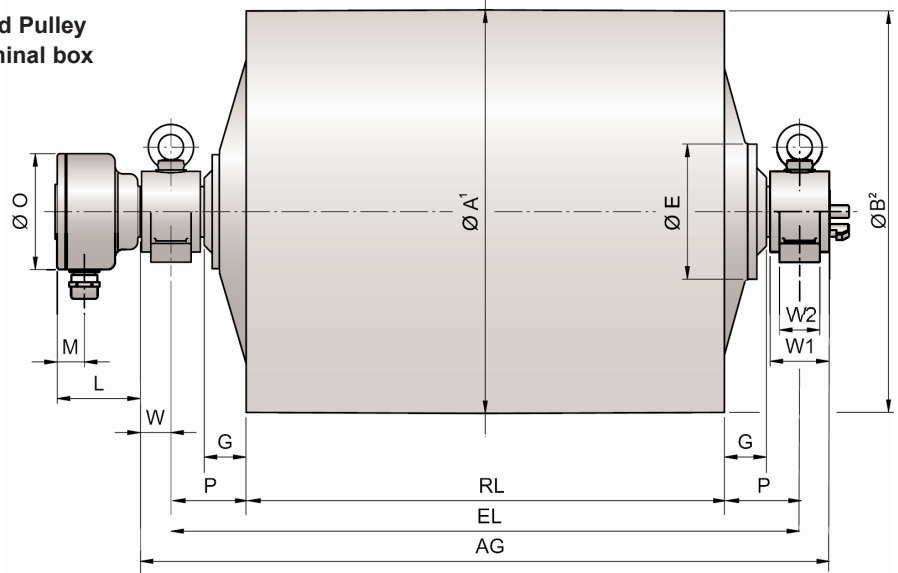

Motorized Pulley 800M & 800H, Ø 31.50 in. (800 mm)

Motorized Pulley with terminal box



Idler Pulley³
UT630M / UT630H

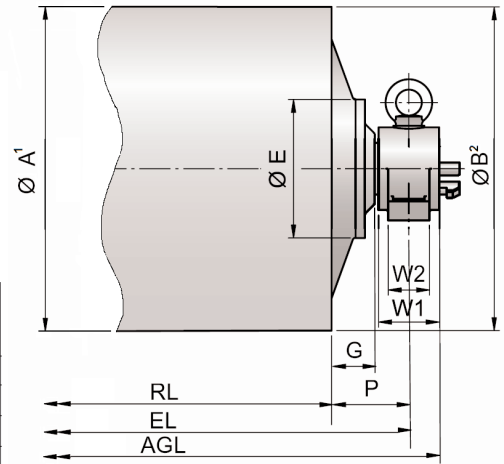

Motorized Pulleys or Idler Pulleys

Model	A in	B in	C in	D ⁴ in	E in	G in	L in	M in	O in	P in
800M	31.50	31.34	-	3.54	10.55	3.46	6.50	2.13	9.06	5.91
800H	31.50	31.34	-	4.72	12.99	3.15	7.87	2.44	10.24	5.91
UT630M	24.80	24.80	-	3.54	8.90	3.35	-	-	-	5.91
UT630H	24.80	24.80	-	4.72	12.99	2.95	-	-	-	5.91

- 1 A dimension is outer diameter of unlagged pulley shell at pulley centerline.
- 2 B dimension is outer diameter of unlagged pulley shell at each end of shell.
- 3 Idler pulley shown is non-crowned version.
- 4 D dimension is shaft diameter.

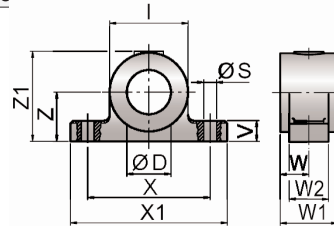

Mounting brackets*

Motorized Pulleys & Idler Pulleys Model	Material	Bracket Size*	Dimensions											Weight lbs
			D in	I in	S in	V in	W in	W1 in	W2 in	X in	X1 in	Z in	Z1 in	
800M & UT630M	Cast steel	AL90/ALO90	3.54	6.30	1.02	1.65	2.40	4.61	3.15	9.84	12.60	3.94	7.20	41.89
800H & UT630H	Cast steel	AL120/ALO120	4.72	7.87	1.30	1.97	3.74	6.30	4.72	11.81	14.57	4.33	8.39	83.78

* Type AL bracket has gib key. Type ALO has no gib key. See position 69 on page 68.