

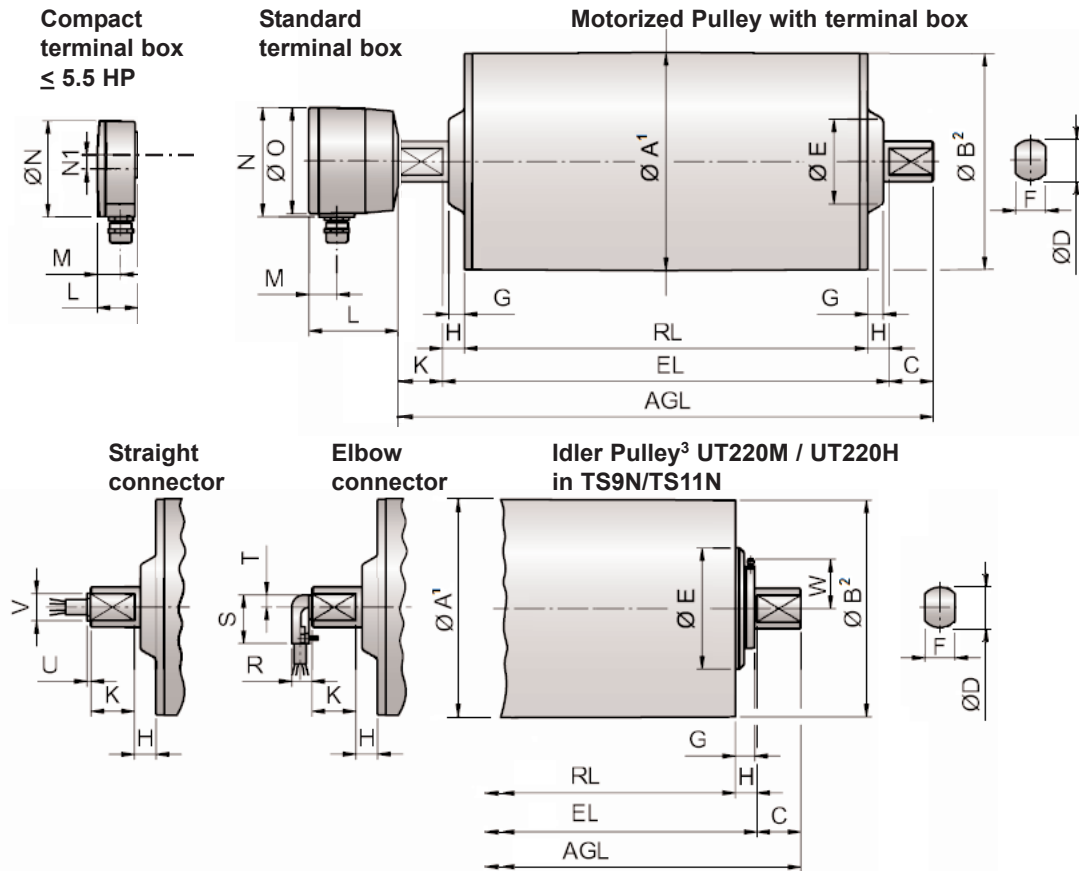

# Motorized Pulley 220M & 220H, Ø 8.50 in. (216 mm)



Model	Motorized Pulley or Idler Pulley											Standard terminal box				Compact terminal box ≤ 5.5 HP				Straight connector ≤ 5.5 HP		Elbow connector ≤ 5.5 HP		
	A	B	C	D	E	F	G	G	H	K	W	L	M	N	O	L	M	N	N1	U	V	R	S	T
	in	in	in	in	in	in	in	TS9/11 in	in	in	in	in	in	in	in	in	in	in	in	in	in	in	in	in
220M & 220H	8.50	8.44	1.71	1.57	3.94	1.18	0.61	0.77	0.85	1.63	-	3.43	1.06	4.21	4.13	1.61	0.95	3.74	0.55	0.16	1.06	0.79	1.89	0.47
UT220M & UT220H	8.50	8.50	1.71	1.57	3.94	1.18	0.61	0.77	0.85	-	2.05													

- 1 A dimension is outer diameter of unlagged pulley shell at pulley centerline.
- 2 B dimension is outer diameter of unlagged pulley shell at each end of shell.
- 3 Idler pulley shown is non-crowned TS9N/TS11N version with regreasable seals.

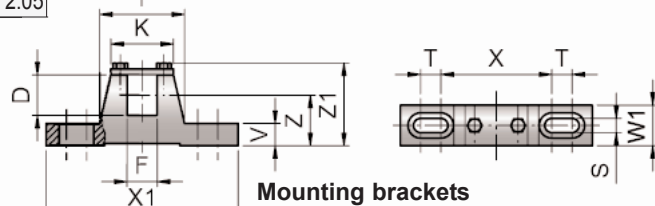

Motorized Pulleys	Material	Bracket Size	Part Number	Dimensions													Weight
				D	F	I	K	S	T	V	W1	X	X1	Z	Z1		
Model				in	in	in	in	in	in	in	in	in	in	in	in	in	lbs
220M & 220H	Steel painted	KL41-HD	6YA0K	1.57	1.18	3.31	2.44	0.55	0.79	0.87	1.57	4.33	7.48	1.97	3.27	4.63	
	Steel Ni plated		6YA0W														
	Stainless steel		6YA0U														